

**CRYOGENIC RECIPROCATING PUMPS
FOR LIQUEFIED GASES**

★ DISTRIBUTION
CRYOSTAR



THE CRYOSTAR GROUP

As a pioneer in the design and manufacture of cryogenic equipment, CRYOSTAR started out in 1967 producing cryogenic pumps for liquefied industrial gases. The company has become a major actor in the field of industrial and medical gases, clean power generation, LNG and hydrocarbon applications. CRYOSTAR brings to you over 50 years of experience and know-how.

With its headquarters located in France and Business Centers in Brazil, China, India, Russia, Singapore, the United Kingdom, and the United States of America, along with numerous partners, CRYOSTAR is always close to customers, available and ready to act. CRYOSTAR employs close to 650 people all over the world. They are CRYOSTAR's strongest asset. Together they share the same values to support the company towards ever greater innovation, technology and knowledge.

CRYOSTAR has equipped thousands of plants. Cryogenic pumps, expansion turbines, cryogenic compressors, small scale liquefaction plants, LNG vaporizers, cylinder filling stations, and natural gas fueling stations... these are at the heart of CRYOSTAR's products range.

To optimize your plant availability and consequent uptime, CRYOSTAR also offers full service solutions : on-site installation and commissioning based on strict safety standards (24/7 technical support, service contracts, on site training support), maintenance and repair (technology updates, factory and on-site maintenance agreements), as well as equipment lifelong recurrent and uptodate training sessions. Through our locations based on all continents, we make sure there is always a CRYOSTAR helper near you.

★ Innovate

★ Take up challenges

★ Have a passion for excellence

★ Be generous in what we do

★ Respect and empower our people

★ Act with integrity

VISION VALUES



We are a leading innovative company, sustainably providing proactive customer service, supported by a strong culture encompassing skilled and engaged personnel.

Samuel ZOUAGHI
President

Headquarters in France



WORLDWIDE PRESENCE

CRYOSTAR company ensures a local presence for sales and service through its business centres and business partners network.



CRYOSTAR offers solutions to minimise downtime for its machines such as maintenance contracts, spare parts management and remote maintenance.





Product specialists will give you technical assistance by phone, and can launch an urgent intervention where necessary.

CRYOSTAR
CUSTOMER CONTACT

+33 (0)3 89 700 700

welisten@cryostar.com



-  CRYOSTAR Business Centers
-  Certified service partner



*: service partners able to do service on road tanker could also modify the external piping to replace an existing type of pump with another one.

INNOVATION

At CRYOSTAR, innovation is at the heart of everything we do, not just for teams dedicated to Research & Development, but also for teams who work every day to design the equipment we sell.

A community of Experts, Specialists and Referents also capitalizes on their own experience and the feedback received from customers to continue to innovate.



TESTING

Every product (be it fresh off the assembly line or recently refurbished) is subject to stringent testing on CRYOSTAR cryogenic test facility.

The performance test with liquid nitrogen ensures guaranteed performance for CRYOSTAR customers.

A copy of the performance test is systematically included in the instruction and operating manual delivered together with the equipment.

Test tank capacities	200m ³ + 54m ³ + 16m ²
Number of lines	10 + 2 (HP)
Flow rate	up to 20'000 l/min
Operating pressure	up to 700bar
Power	up to 2 MW



HEALTH, SAFETY, ENVIRONMENT

CRYOSTAR's HSE policy is based on a double certification: **OHSAS 18001 and ISO 14001** (V2015).

This structuring approach made it possible to anchor continuous improvement in the company's culture. CRYOSTAR guarantees its machines' compliance with customer specifications and the regulations in the country where they are installed to enable customers to operate equipment with complete confidence. **Safety of both property and people is our priority.**

CRYOSTAR is committed to the social and societal area for its employees' well-being. Therefore, diversity, balance and well-being at work, are notions which CRYOSTAR views as being of vital importance through targeted actions at the heart of its human resources policy.



QUALITY

The Quality department features a large and highly qualified multi-disciplinary team, which is involved in implementing Quality strategy in areas of the utmost importance:

- ★ Metrology / Quality System
- ★ Supplier Quality
- ★ Operational Quality
- ★ Engineering Quality
- ★ Product Safety



TRAINING

CRYOSTAR Training Center offers training sessions adapted to all the equipment and solutions.



Theoretical courses can be combined with practical sessions, depending on the availability of the equipment on the customer's site or in CRYOSTAR's factory.

- ★ Get the best out of your equipment
- ★ Maintain the equipment safely & efficiently
- ★ Improve your awareness to increase the MTBF



TYPICAL RECIPROCATING PUMP INSTALLATION

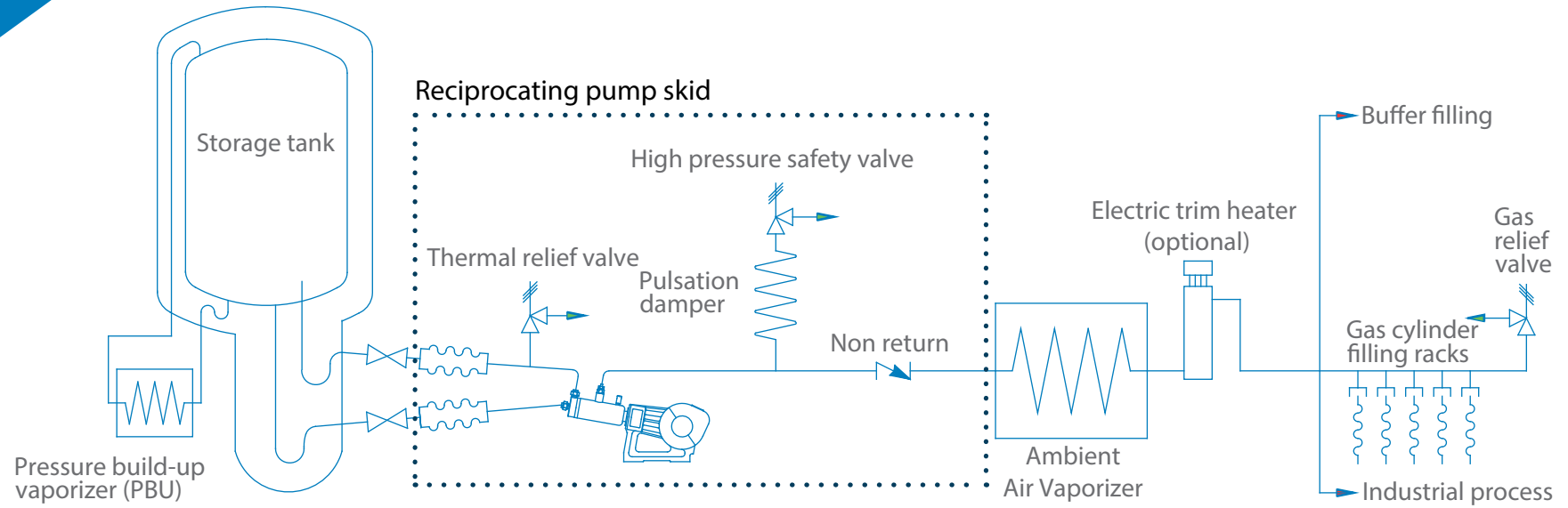

CONVENTIONAL TANK

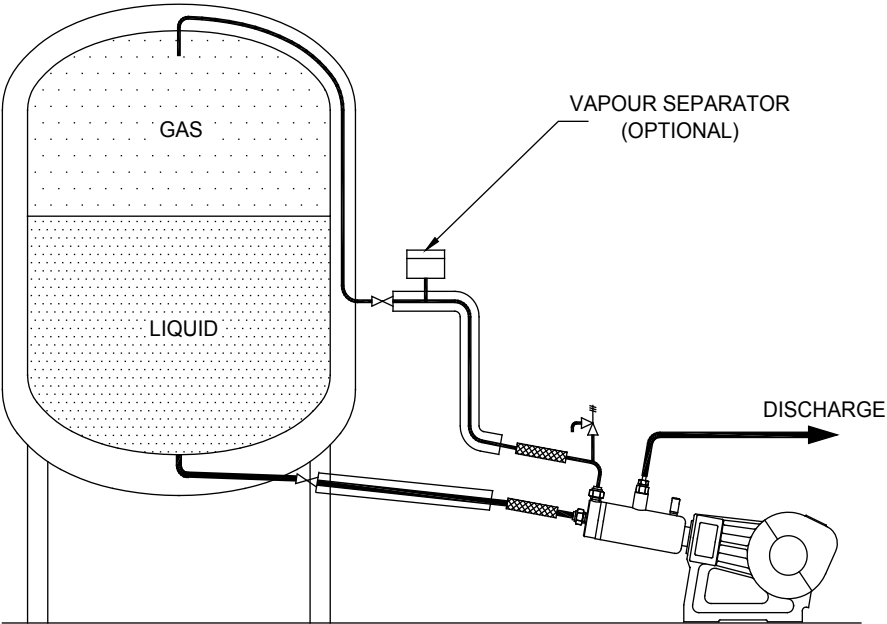

THERMOSYPHON TANK

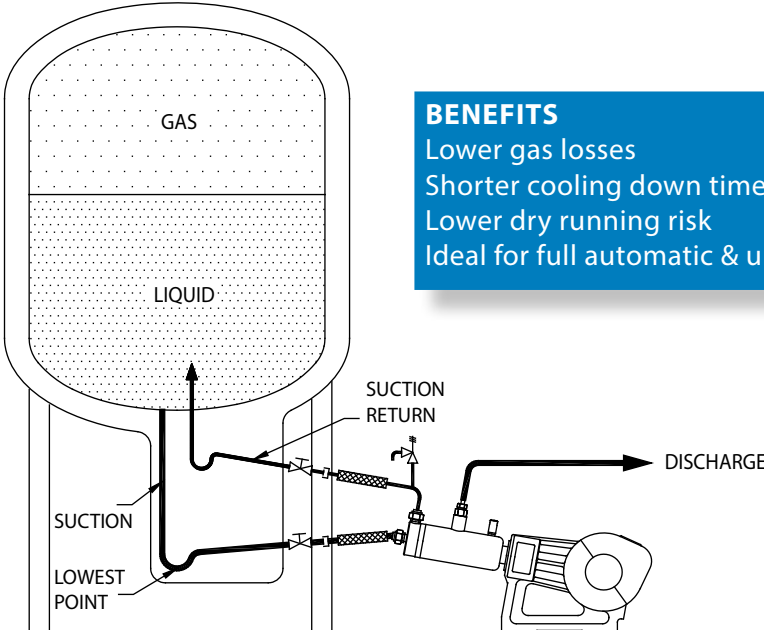

BENEFITS
 Lower gas losses
 Shorter cooling down time
 Lower dry running risk
 Ideal for full automatic & unattended operation

A-
Skid

XXX
Cold End type

XXX /
Piston diameter
(mm)

XX -
Stroke
(mm)

XX
Execution

OLX
Crank drive

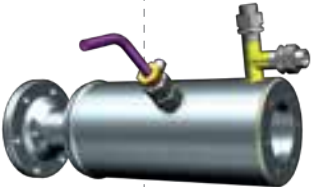

PPC
SDPD
SRP
MRP
LDPD
HPP



-K: suction head
for conventional tank

-T: suction head
for thermosyphon tank

OL & OL1: simplex
OL2: duplex
OL3: triplex

Example: **A-MRP 40/55-T OL1**



COMPREHENSIVE RANGE OF RECIPROCATING PUMPS

CYLINDER FILLING PUMPS FOR INDUSTRIAL & MEDICAL GASES



PPC



SDPD



SRP / MRP

	PPC	SDPD	SRP / MRP
Gases	LCO ₂ , LN ₂ O	LO ₂ , LN ₂ , LAr, LCO ₂ , LN ₂ O	Ind. LO ₂ , Med. LO ₂ , LN ₂ , LAr, LCO ₂ , LN ₂ O
Design pressure	120bar	320bar	380 / 500bar
Cold End	No insulation	Vacuum insulated	Vacuum insulated with long life seals
Crank drive	Grease lubricated	Grease lubricated	Oil lubricated

HIGH DUTY PUMPS FOR CUSTOMER APPLICATIONS & LNG



MRP & LDPD Simplex, Duplex & Triplex



HPP Simplex & Triplex

	MRP & LDPD Simplex, Duplex & Triplex	HPP Simplex & Triplex
Flow rate	340 l/min (~13'000 Nm ³ /h of N ₂)	520 l/min (~18'500 Nm ³ /h of N ₂)
Cold End	Vacuum insulated with long life seals	Vacuum insulated with long life seals
Crank drive	Oil lubricated	Oil lubricated (with gearbox above 400kW)

INDUSTRY	APPLICATION	PRESSURE	PUMP TYPE
Industrial, Food & Medical Gases	Gas cylinder filling	500bar	SDPD, SRP, MRP
	Liquid cylinder filling	120bar	PPC, SRP, MRP
	High pressure testing / Inerting / Wobbing	400bar	MRP, LDPD, HPP
Liquid Hydrogen	Compressed tube trailers / Fuel cell refueling	500bar	MRP
Liquid Natural Gas & Biogas	CNG vehicle refueling	350bar	MRP
	Peak shaving / High pressure engines	500bar	SRP, MRP
Other gases (Liquid ethylene, Ethane, Neon, Sulfur hexafluoride...)	Hydrocarbon processing / Gas compressing	300bar	MRP, LDPD, HPP
		500bar	MRP, KPL, HPP

Pressure (bar)

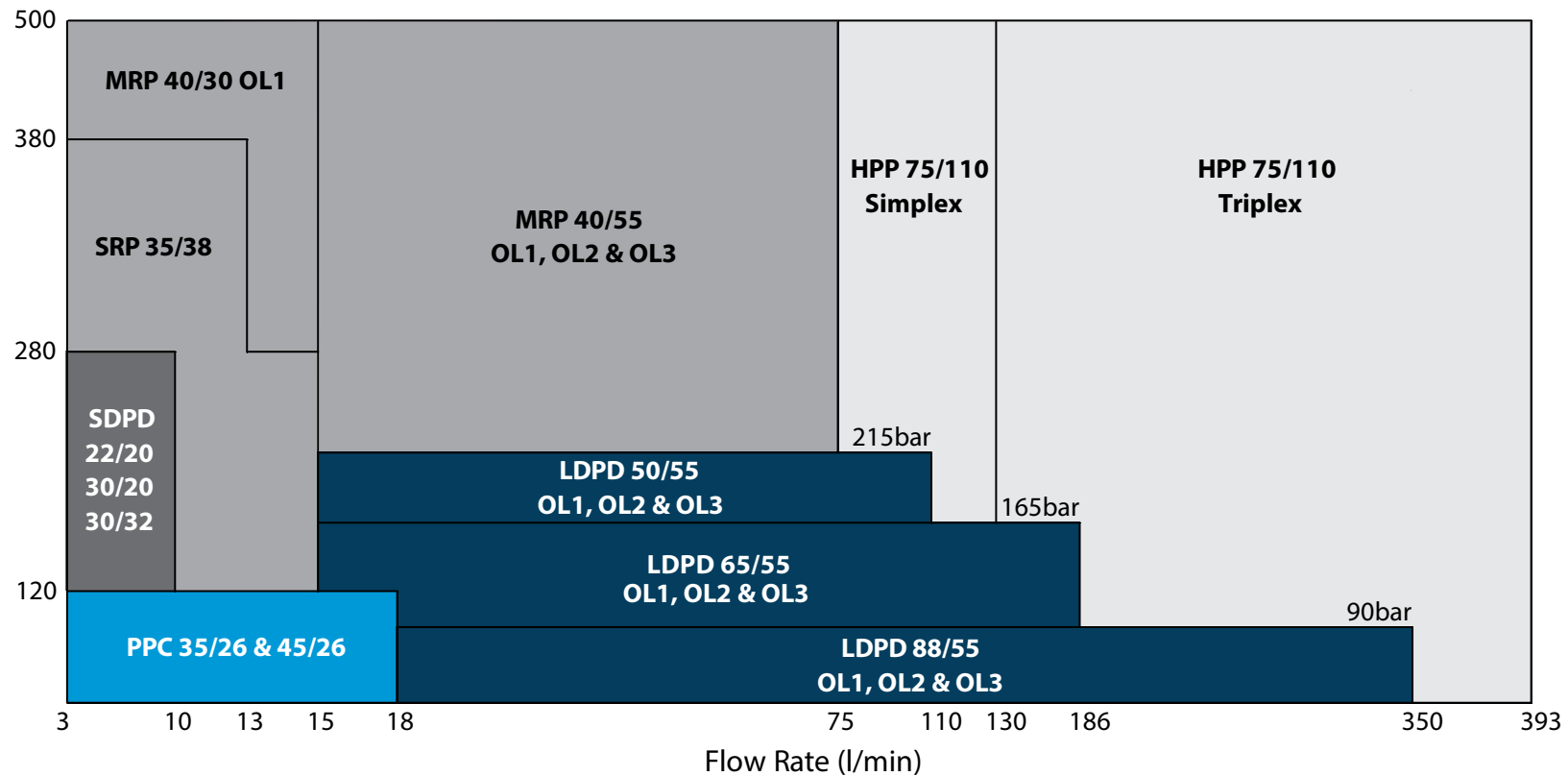

CRYOGENIC HIGH PRESSURE PUMPS



Maximum Safety

- ★ Oxygen compatible material / 100% filtration
- ★ Rugged coupling
- ★ Compliance with Pressure Equipment Directives



Minimum Product Losses

- ★ High vacuum insulation
- ★ High hydraulic efficiency insulation
- ★ Improved high pressure seals



Low NPSH Requirement

- ★ High efficiency suction valve
- ★ Large suction chamber
- ★ Improved degassing design



Maximum Reliability (longer maintenance intervals)

- ★ Large sealing area (thermal stability)
- ★ Long life low pressure seals (CRYOSTAR design)
- ★ Oil lubricated crank drive

RECIPROCATING PUMPS – DESIGN

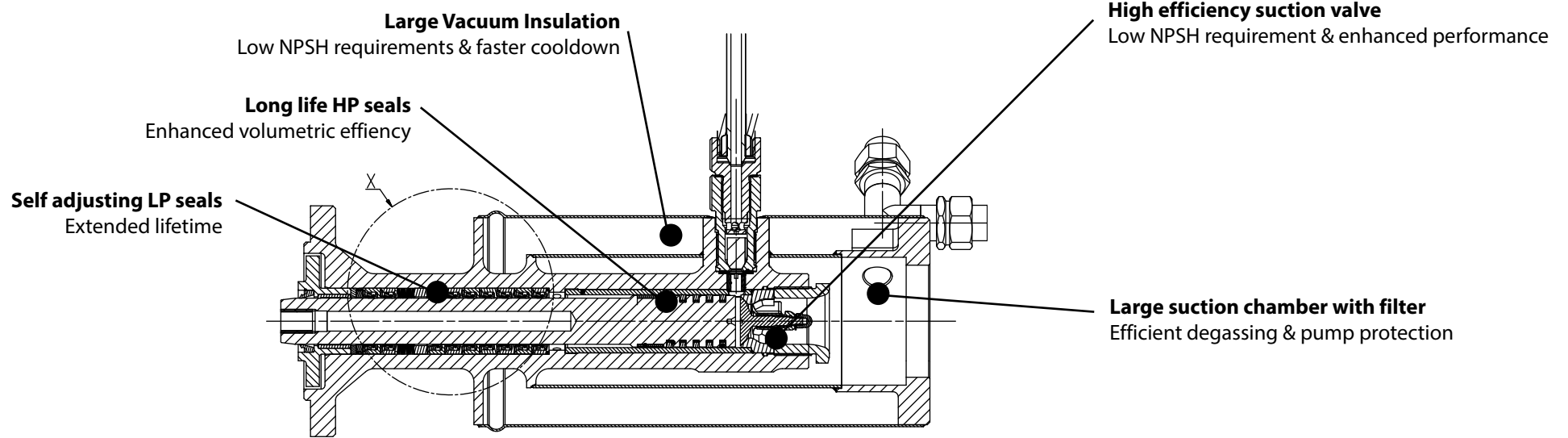

HIGH DUTY PUMPS FOR CUSTOMER APPLICATIONS & LNG

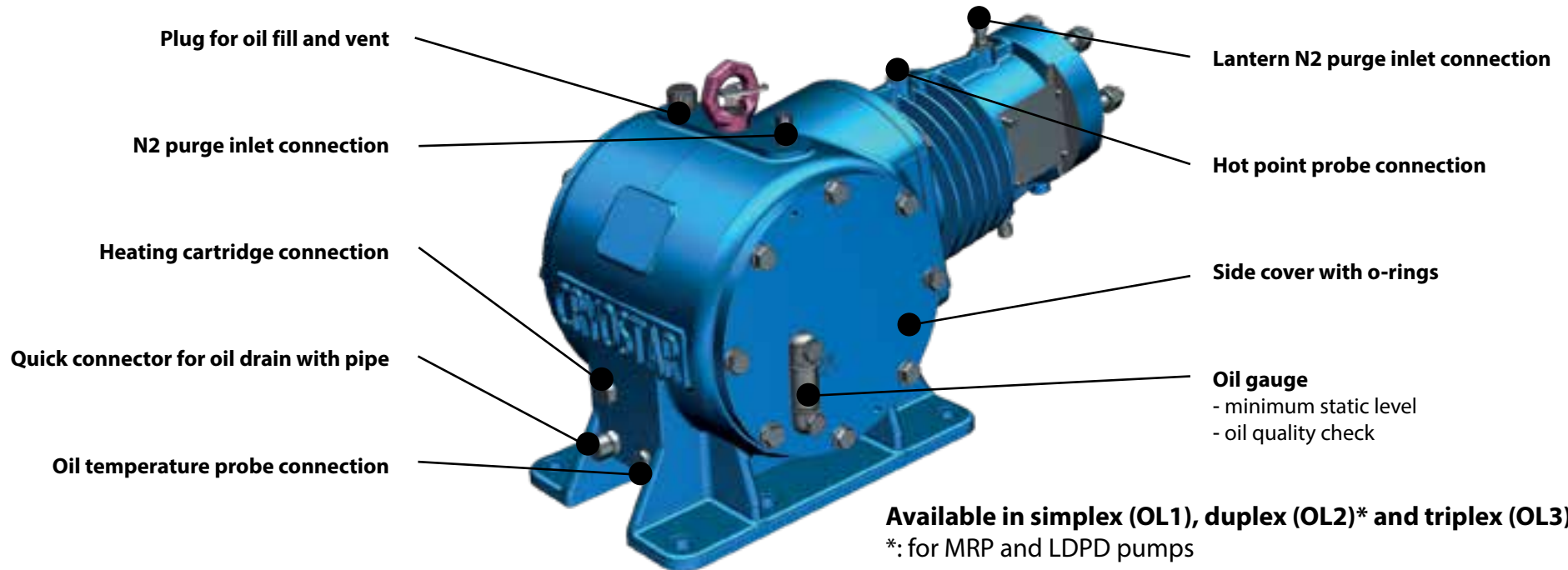



INDUSTRIAL GASES HIGH PRESSURE CYLINDER FILLING (LO₂/LN₂/LAR)

NEW SRP 35/38 FOR SMALL & MID-SCALE FILLING PLANTS



Flow rate	Up to 15 l/min
Design pressure	380 bar
Power	Up to 18,5 kW

MRP 40/55 OL1 FOR MID & LARGE-SCALE FILLING PLANTS



Flow rate	Up to 25 l/min
Design pressure	550 bar
Power	Up to 45 kW

INDUSTRIAL PROCESSES & NITROGEN APPLICATIONS

MRP, LDPD AND HPP



Flow rate	Up to 393 l/min
Design pressure	520 bar
Power	Up to 500 kW

SKID CONSTRUCTION

- ★ Oxygen compatible lubricants
- ★ Certified according to **CE PED 97/23 / EC**
- ★ Designed and built in accordance with the **Machinery Directive 2006/42 / EC Machine**
- ★ Stainless steel base frame for **long-lasting durability**
- ★ **Compact packaged unit** including **safety valves and emergency stop** for maximum safety

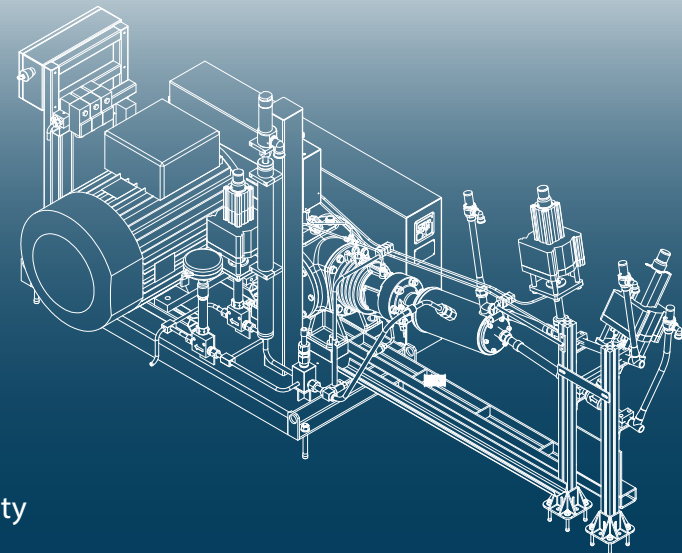



LIQUID TO COMPRESSED NATURAL GAS PUMP (LCNG)

MRP 40/55 LNG

- ★ Suitable for compressed Natural Gas & Biogas vehicle refueling
- ★ Full instrumented for highest safety
- ★ Total compliance with ATEX directive
- ★ High reliability design with extended maintenance intervals

Flow rate	Up to 25/50/75 l/min (OL1/OL2/OL3)
Design pressure	400 bar
Power	Up to 90 kW



LIQUID TO COMPRESSED HYDROGEN PUMP (LCGH2)

MRP 40/55 LH2

The MRP LH2 for hydrogen has been **designed to reduce to a minimum any loss of fluid** during cooling down & cold standby.

- ★ Reduced mass
- ★ Increased insulation (vacuum volume, thermal barrier)
- ★ Anti-radiation barrier
- ★ Dedicated vacuum insulated suction head
- ★ Design calculation considering all stresses related to thermal expansion

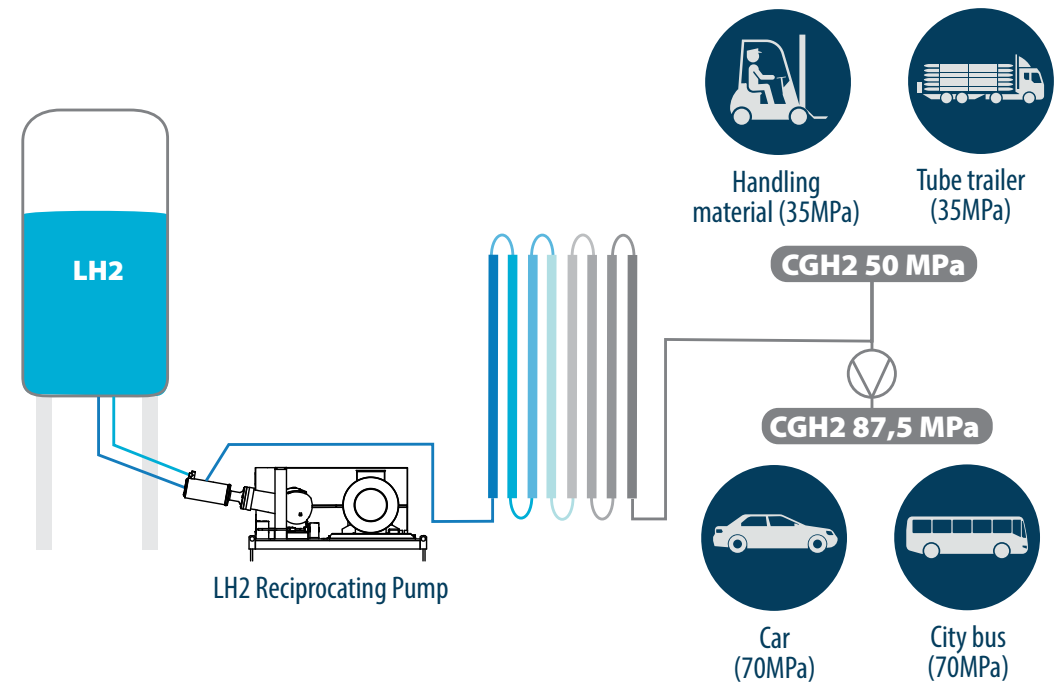

Flow rate	Up to 15/30/45 (OL1/OL2/OL3)
Design pressure	500 bar
Power	Up to 30 kW

Safety warnings

- ★ Risk of **oxygen condensation on piping** (liquefies at -183°C) has to be managed
- ★ **Nitrogen inerting** is mandatory **prior to any dismantling**



BRAZIL

CHINA

FRANCE

INDIA

RUSSIA

SINGAPORE

UK

USA

For contact and address of the CRYOSTAR
locations worldwide, please go to
www.cryostar.com/locations



www.cryostar.com

